

WELCOME  
TO  
PRESENTATION  
ON  
GRID INTERACTIVE ROOF TOP SOLAR PV SYSTEM



By Alok Gupta  
Chief Engineer (Distribution)  
Central Electricity Authority  
09868913762  
[cedpdcea@yahoo.co.in](mailto:cedpdcea@yahoo.co.in) 1  
[alokgupta53@yahoo.co.in](mailto:alokgupta53@yahoo.co.in)

**TASK FORCE BY MNRE**

**Three Sub Groups by Task Force**

Sub-Group-I	Grid connectivity issues of roof top solar PV Systems
Sub-Group-II	To look into feasibility of integrating Solar Generation with Thermal Power Plants
Sub-Group-III	To look into feasibility of integrating Solar Generation with Hydro Power Plant

2

## SUB GROUP-I

- SUB-GROUP-I----- CEA,MOP,MNRE,BEE,NHPC,BHEL,KPCL,NDPL
- TO BRING OUT GUIDELINES ON INTERCONNECTION OF SOLAR ROOFTOP SYSTEM TO THE GRID ONE EACH FOR
  - COMMERCIAL BUILDING
  - INDEPENDENT HOUSE
- GUIDELINES TO INCLUDE TECHNICAL REQUIREMENTS.
- SUBGROUP I TO PREPARE A FEASIBILITY REPORT FOR INSTALLING SOLAR PLANT IN LEH REGION AND SEWA BHAWAN.

3

## ISSUES ADDRESSED IN REPORT

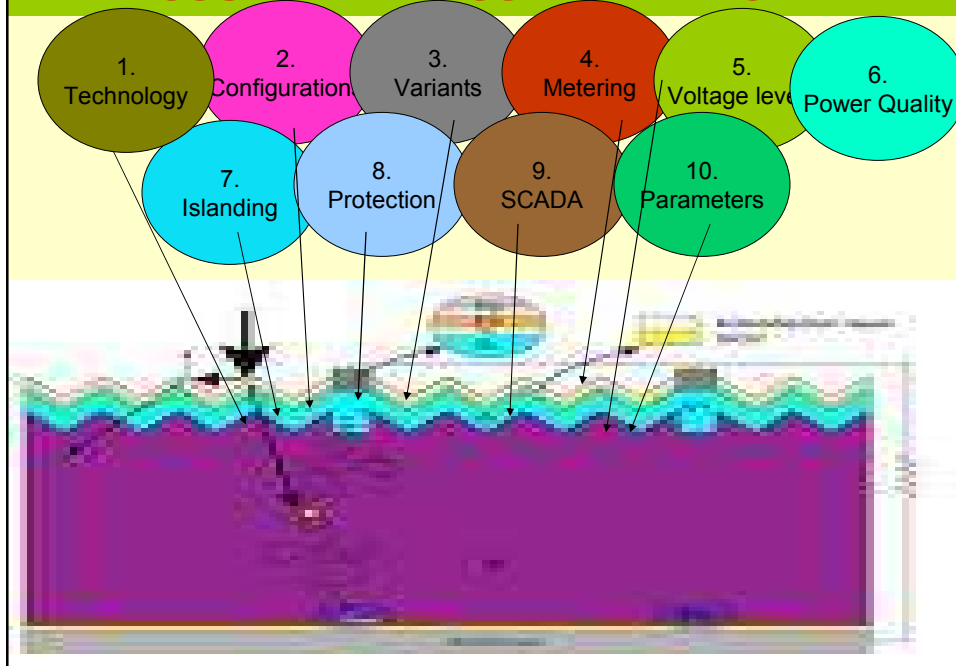

# 1. TECHNOLOGY-PV MATERIAL EFFICIENCIES(%)

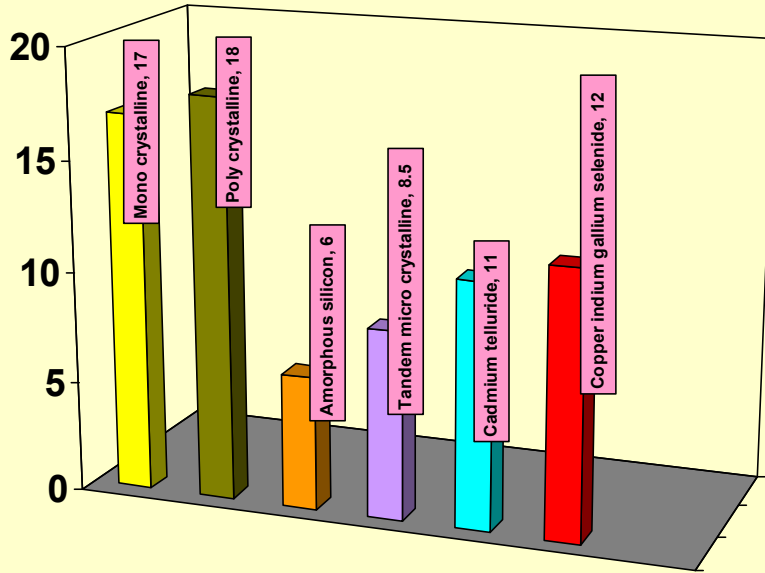

5

# COST ALLOCATION OF PV SYSTEM(%)

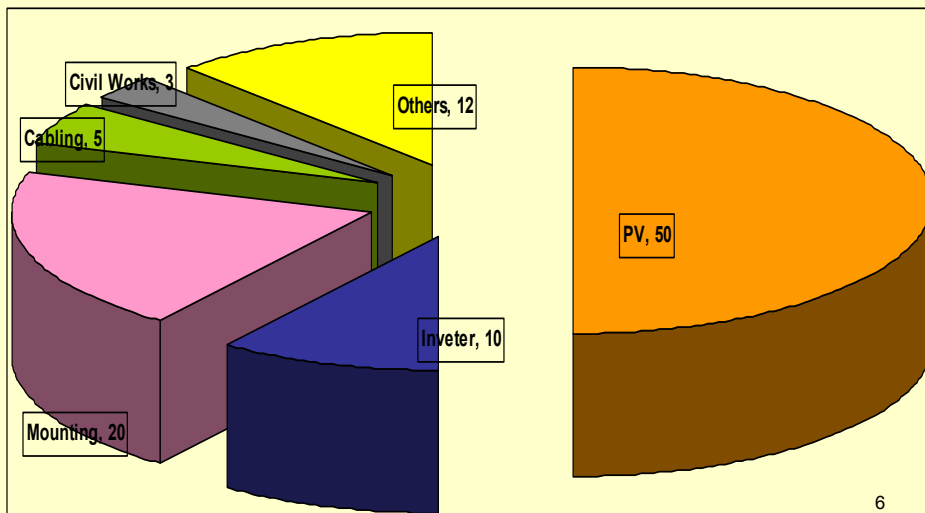

6

## 2. CONFIGURATION

### WITHOUT BATTERY

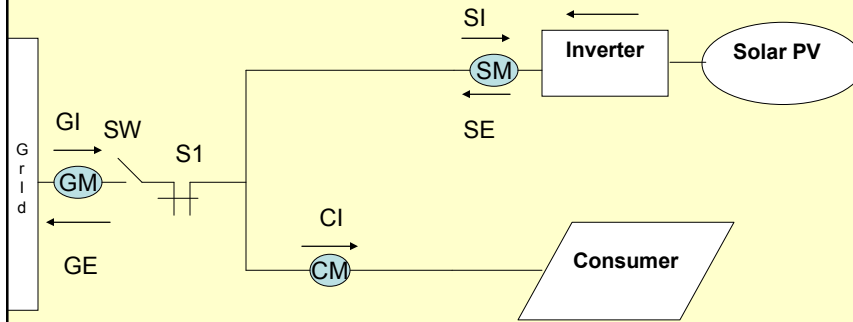

Normally solar is connected with the grid. When grid fails inverter controlled switch S1 will open automatically.

SM-Solar Meter  
GM-Grid Meter  
CM-Consumer Meter

## CONFIGURATION contd

### WITH BATTERY

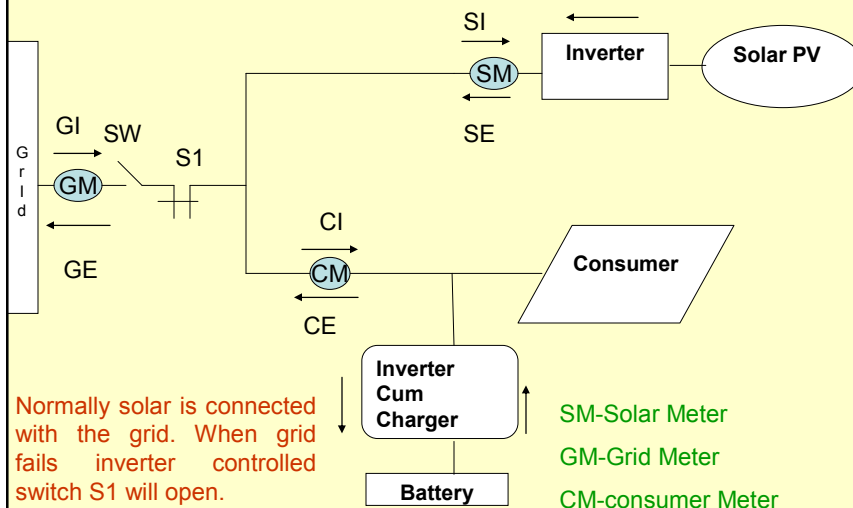

Normally solar is connected with the grid. When grid fails inverter controlled switch S1 will open.

SM-Solar Meter  
GM-Grid Meter  
CM-consumer Meter

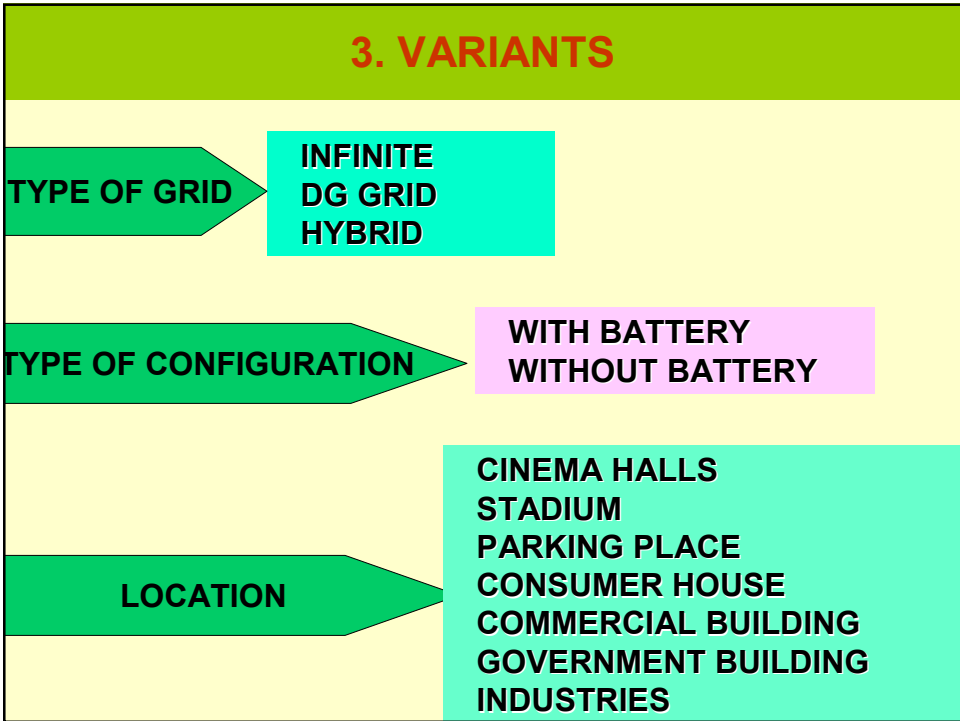
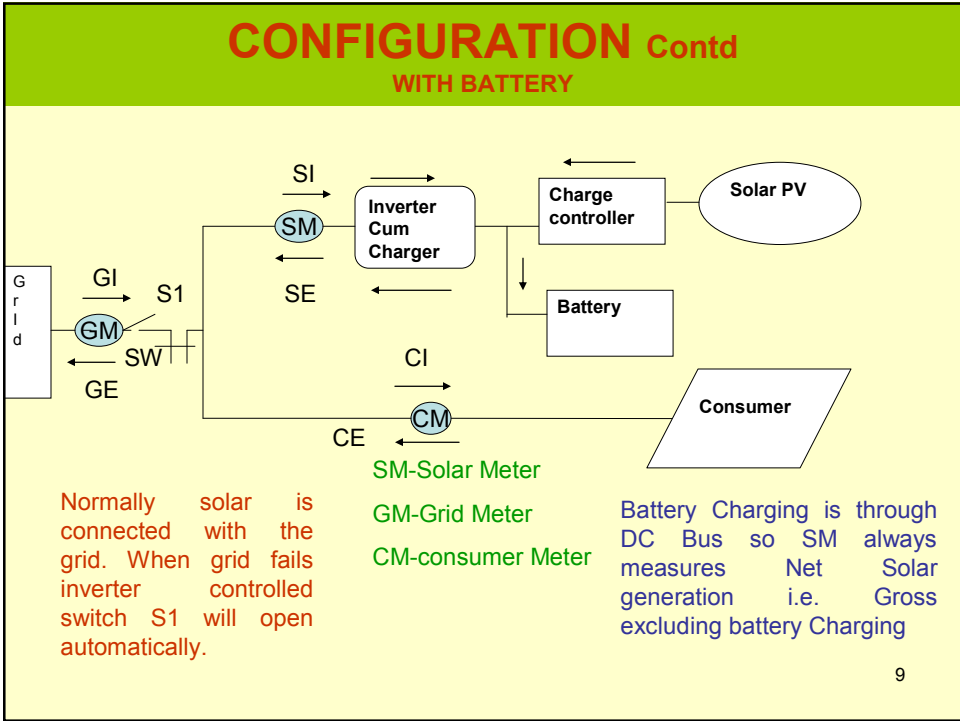

<b>SCHEMES</b>	
<b>SI No</b>	<b>Scheme Description</b>
1	Grid interactive Solar PV System without Battery.
2	Grid interactive Solar PV System with full load Battery backup.
3	Grid interactive Solar PV System with Partial load Battery backup
4	Grid Interactive Solar PV System With Full Load DG Backup
5	Grid Interactive Solar PV System With Partial Load DG Backup
6	Grid Interactive Solar PV System With Full Load Battery and DG Backup
7	Grid Interactive Solar PV System With Partial Load Battery and DG Backup

<b>4. METERING</b>
<ul style="list-style-type: none"> <li>➤ Billing based on the net energy import from the grid.</li> <li>➤ A Licensee receives credit for net energy supplied to the consumer load in case it is import.</li> <li>➤ Pays to the developer if there is net export to grid.</li> <li>➤ Tariff has to be same for export and import.</li> </ul>
12

## **BOTTELNECK OF NET METERING**

- **IT DOES NOT REWARD PERFORMANCE**
- **IT DOES NOT WORK WELL IF A BUILDING IS NOT OCCUPIED BY THE OWNER.**
- **NET METERING DOES NOT EASILY ACCOMMODATE THIRD PARTY INVESTORS**
- **NET METERING DOES NOT ALLOW AN INVESTOR TO EASILY CAPTURE THE FUTURE VALUE OF THE ELECTRICITY PRODUCED.**
- **NET METERING PROVIDES DIFFERENT PRICES FOR PV ENERGY FOR DIFFERENT CUSTOMER CLASSES.**

13

## **METERING- FEED IN TARRIF**

- **NO PRICE SYMETRY OF NET METERING**
- **CONSUMER PAYS RETAIL RATE FOR THE ELECTRICITY THEY USE, AND THE POWER PROVIDER PURCHASES THEIR EXCESS GENERATION OR ENTIRE GENERATION AT ITS AVOIDED COST (WHOLESALE RATE).**
- **THERE MAY BE A SIGNIFICANT DIFFERENCE BETWEEN THE RETAIL RATE THE USER PAYS AND THE POWER PROVIDER'S AVOIDED COST.USUALLY IT IS 3-4 TIMES THE RETAIL TARIFF.**

14

## **METERING (Net) – FOREIGN COUNTRIES**

<b>USA</b>	-	<b>NET METERING. NOW SWITCHING TO FIT METERING</b>
<b>CANADA</b>	-	<b>ONTARIO-NET METERING UPTO 500 KW BUT CREDIT PERIOD IS DIFFERENT FROM TIME TO TIME.</b>
<b>UK</b>	-	<b>BRITISH COLUMBIA-NET METERING UPTO 50 KW PILOT PROJECTS ARE UNDERWAY.</b>
<b>KANAS</b>	-	<b>RENEWABLE METERING INCENTIVE ON WHOLESALE LEVEL AT 150% OF AVOIDED COST.</b>
<b>NEW JERSEY-</b>		<b>SYSTEM SIZE IS LIMITED TO 2 MW.</b>

15

## **METERING (FIT)-FOREIGN COUNTRIES**

<b>AUSTRALIA</b>	<b>(EXPORT TO GRID IS AT HIGHER RATE SAY 60 CENTS)</b>		
<b>BRAZIL</b>	<b>CHINA</b>	<b>CYPRUS</b>	<b>CHEKESLOVAKIA</b>
<b>DENMARK</b>	<b>ESTROIA</b>	<b>FRANCE</b>	<b>NEW JERSEY</b>
<b>GERMANY</b>	<b>GREECE</b>	<b>HUNGRY</b>	
<b>IRAN</b>	<b>IRELAND</b>	<b>ITALY</b>	<b>ISRAEL</b>
<b>KOREA</b>	<b>LITHUANIA</b>	<b>LUXEMBOURG</b>	
<b>NETHERLANDS</b>	<b>PORTUGAL</b>	<b>SINGAPORE</b>	<b>SPAIN SWEDEN</b>
<b>SWITZERLAND</b>	<b>AND</b>	<b>IN SOME STATES IN USA.</b>	

16

## **METERING REQUIREMENTS**

- MEASURE LOAD CONSUMPTION
- MEASURE SOLAR GENERATION
- MEASURE BATTERY CHARGING CONSUMPTION
- MEASURE GRID IMPORT AND EXPORT

## **TYPE OF METERING**

- **BOTH NET METERING AND FEED IN METERING STUDIED BY SUBGROUP**
- **SUGGESTED FEED IN TARIFF METERING IN LINE WITH GOVT POLICY**

17

## **CEA REGULATIONS METERING-COMPLIANCE**

- LOCATION
- ACCURACY
- PERIODICITY OF TESTING
- PARAMETERS
- TAMPER FEATURES
- DATA DOWNLOADING FACILITY

18

## ENERGY METERS-SPECIFICATIONS

- **APPLICABLE IS- 13779 OR IS 14679**
- **REGULATIONS CEA METERING REGULATIONS 2006**
- **ACCURACY CLASS- 1.0 or Better up to 650 V**  
**0.5 S or Better- Above 650 V-up to 33 KV**  
**0.2 S Above 33 KV**
- **METERING PARAMETERS - BOTH EXPORT AND IMPORT**
  - 8 TIME ZONES
  - MAXIMUM DEMAND
  - DOWN LOADING FACILITY
  - TAMPER RECORDING
  - SIX BILLING CYCLE DATA

19

## 5. VOLTAGE LEVELS

- UP TO 10 kW -LOW VOLTAGE SINGLE PHASE SUPPLY.**
- UPTO A LEVEL OF 100 KW- 3 PHASE LV SUPPLY**
- MORE THAN 100 KW AND UPTO 1.5 MW- 11 KV LEVEL.**
- MORE THAN 1.5 MW AND UPTO 5 MW- 33 KV LEVEL.**

**SYSTEM VOLTAGE VARIATION-  $\pm 10\%$**

20

## 6. POWER QUALITY REQUIREMENTS

<b>DC INJECTION INTO GRID</b>	1% (OF RATED AC CURRENT)
<b>RIPPLE CONTROL ON DC SIDE</b>	RIPPLE CONTENT SHALL NOT EXCEED 5%
<b>VOLTAGE FLUCTUATIONS</b>	REPETITIVE STEP CHANGES-1.5%. FOR OCCASIONAL FLUCTUATIONS-3%.
<b>VOLTAGE UNBALANCE</b>	<b>3%</b>
HARMONICS	LIMITS FOR HARMONICS SHALL BE AS STIPULATED IN THE CEA REGULATIONS ON GRID CONNECTIVITY. <span style="float: right;">21</span>

## 7. ISLANDING

### UNDER VOLTAGE

- IT IS PROPOSED THAT GRID VOLTAGE BE MONITORED CONTINUOUSLY AND IN THE EVENT OF VOLTAGE GOING BELOW 80% AND ABOVE 112.5%, THE SOLAR SYSTEM SHALL BE DISCONNECTED FROM THE GRID WITHIN TWO SECONDS AS PER AS4777 STANDARD (AUSTRALIA).

### NO GRID VOLTAGE

- THE INVERTER AUTOMATICALLY SWITCHES TO OFF-GRID SUPPLY WITHIN 20-50 MILLISECOND IN CASE OF GRID FAILURE.

22

## 8. PROTECTION

- ❖ OVERCURRENT AND OVERLOAD PROTECTION AGAINST SHORTCIRCUIT ON AC AND DC SIDE INCLUDING STRING PROTECTION
- ❖ BATTERY OVERCHARGING AND OVER DISCHARGE PROTECTION
- ❖ BATTERY OVERLOAD PROTECTION.
- ❖ LIGHTENING PROTECTION
- ❖ GROUND FAULT PROTECTION SYSTEM.
- ❖ REVERSE POLARITY PROTECTION
- ❖ OTHER PROTECTION AS PER MANUFACTURER'S PRUDENT PRACTICE.

23

## 9. SCADA

- SCADA for above 25 kWp System.
- SCADA for following functions
  - real time data logging
  - event logs
  - supervisory control
  - Operational modes
  - Set point editing
- The data acquisition system (DAS) furnishes
  - DC parameters – Volts, Current & kW.
  - AC parameters – Volts, Current & kW, kVA, kWh, Hz, PF, MD, TOD parameters, Tamper records

24

10. PARAMETERS							
ROOF AREA NEEDED (SQUARE FEET)							
PV MODULE EFFICIENCY (%)	PV CAPACITY RATING (WATTS)						
	100	250	500	1000	2000	4000	10000
4	30	75	150	300	600	1200	3000
8	15	38	75	150	300	600	1500
12	10	25	50	100	200	400	1000
16	8	20	40	80	160	320	800 25

PARAMETERS FOR SELECTION OF ROOFTOP SPV							
DC output of PV Array (KWp)	0.5	1	3	5	10	25	50
Area required (square feet)	75	150	450	750	1500	3750	7500
No. of cells in one PV module	36	36	72	72	72	72	72
DC rating of one module (W <sub>p</sub> )	80	80	160	160	160	160	160
Connection configuration	Cells are connected in series to form one PV module.						
Rated DC current of one module	4.45	4.45	4.45	4.45	4.45	4.45	4.45
Rated DC voltage of one module (V <sub>mpp</sub> )	18	18	36	36	36	36	36
No. of PV module in one array (all in series)	2	2	5	5	5	10	10
Max. DC output voltage of Array (Volt)	36	36	180	180	180	360	360
No. of Arrays	4	7	4	7	14	16	32
Rating of inverter (KVA)	0.6	1.1	4	6	12	30	60
Nominal AC output voltage (volt)	240	240	240	240	440	440	440
Variation In Output Voltage	±1%	±1%	±1%	±1%	±1%	±1%	±1%
Nominal frequency (Hz)	50	50	50	50	50	50	50
Grid Frequency variation	±3%	±3%	±3%	±3%	±3%	±3%	±3%
No. of phases/ wire	½	½	½	½	¾	¾	¾
AC output voltage range (Grid)	-20% to 15%						26

## SELECTION OF ROOFTOP SPV

Power Factor Range	0.8 lag to unity						
Minimum Efficiency of Inverter (%)	94	94	94	94	94	94	94
No load Losses of Inverter (max)	1%	1%	1%	1%	1%	1%	1%
DC Injection into Grid (max)	1%	1%	1%	1%	1%	1%	1%
Ripple content on DC side	3%	3%	3%	3%	3%	3%	3%
Total Voltage harmonic Distortion (AC side)	5%	5%	5%	5%	5%	5%	5%
Individual Voltage harmonic Distortion (AC side)	3%	3%	3%	3%	3%	3%	3%
Total Current harmonic Distortion (AC side)	8%	8%	8%	8%	8%	8%	8%

27

## SALIENT POINTS OF TARIFF NOTIFICATION ISSUED BY CERC

- Useful life of SPV is- 25 years.
- Tariff period -13 years.
- Debt equity ratio is- 70:30.
- Loan tenure is- 10 years.
- Rate of interest @ 11.75% per annum.
- Depreciation first 10 years @ 7%, remaining period on pro-rata basis.
- Salvage value- 10%.
- Return on equity- 19% p.a. for 10 years.
- 29% p.a. from 11<sup>th</sup> year onwards.
- Working capital - O&M for 1 month
- - Receivable of two months.
- -Purchase spares @ 15% of O&M expenses.
- O&M expanses Rs 9 lakhs/MW.
- Escalation @ 5.72% p.a.

28

## TARIFF CALCULATION FOR 25 kWp SYSTEM

COST OF PV SYSTEM (Rs Lakhs)	42.5
UNITS GENERATED IN 25 years MWH	42
INTERNAL RATE OF RETURN (%)	8.58
LEVELIZED TARIFF Rs/UNIT	18.45

29

**THANK YOU**

30